

TABLE OF CONTENTS

About the CheXpress CX35	1	CheXpress CX35 Routine Maintenance	14
CheXpress CX35 System Requirements	1	CheXpress CX35 Maintenance Overview	14
CheXpress CX35 Included Equipment	2	Inspect the CX35 Document Track	14
CheXpress CX35 Installation	3	Cleaning the CX35 Image Sensor	14
Unboxing the CX35	3	Using the CX35 Cleaning Mode and a Scanner Cleaning Card	15
CheXpress CX35 Features	4	CheXpress CX35 Troubleshooting	16
External View of the CheXpress CX35	4	Connectivity	16
Rear View of the CheXpress CX35	4	Document Feeding Issues	16
CheXpress CX35 Initial Setup	5	Clearing Jams	16
New User Notice	5	Image Quality	17
Cable Connections and Scanner Placement	5	MICR Errors	17
Installing the Ink Cartridge	6	CheXpress CX35	
Installing the Franker Roller	7	Frequently Asked Questions	18
Exit Door Function and Optional Scan Modes	8	What is the Typical Cleaning Interval?	18
Scan Modes	8	What is the LED Status Light Sequence?	18
Loading Items into the Scanner	9	What About Avoiding MICR Read Head Interference?	18
Testing the Scanner	10	How Long Does the Ink Cartridge Last?	18
Installing the Optional USB Driver	10	What is the Entry Tray Capacity?	18
Installing ScanLite2	10	What is the Exit Pocket Capacity?	18
LED Status Indicator	11	Is It Safe to Use Common Cleaners and Sanitizers on the CX35?	18
LED Status Indicator and Smart Button Operation	11	CheXpress CX35 Specifications	19
Accessing the CX35 Internals	12	FCC Statements	20
Removing the External Covers	12	FCC - Class B	20
Accessing the Image Sensors	12	Digital Check Contact Information	21
Accessing the Internal Document Path	13		

ABOUT THE CHEXPRESS CX35

The CheXpress CX35 is an easy-to-use, low-volume check scanner that scans the front and back side of checks and reads the Magnetic Ink Character Recognition (MICR) code line. The images and data are then transmitted through a Universal Serial Bus (USB) interface to the PC. The CX35 features a single-item manual drop-and-slide feeder that offers multiple modes of operation.

The CX35 is rated at up to 30 documents per minute (DPM) scanning speed. Speeds will vary based on the applications used, the PC processing speeds, and mode of operation.

The CX35 features a smart button that is used for powering the unit on/off, pausing scanning, clearing errors, starting/stopping the cleaning mode, and displays the scanner's status through a built-in LED.

CheXpress CX35 System Requirements

Minimum	Recommended
2.4 GHz dual-core or faster processor 2 GB RAM or more	2.8 GHz dual-core or faster processor 4 GB RAM or more
2 GB free disk space	10 GB free disk space
Windows 11/10, (x86 or x86-64)	Windows 11/10, (x86 or x86-64)
USB 2.0 port	USB 2.0 port
DCC API 20.05	DCC API 20.05 or newer

CHEXPRESS CX35 INCLUDED EQUIPMENT

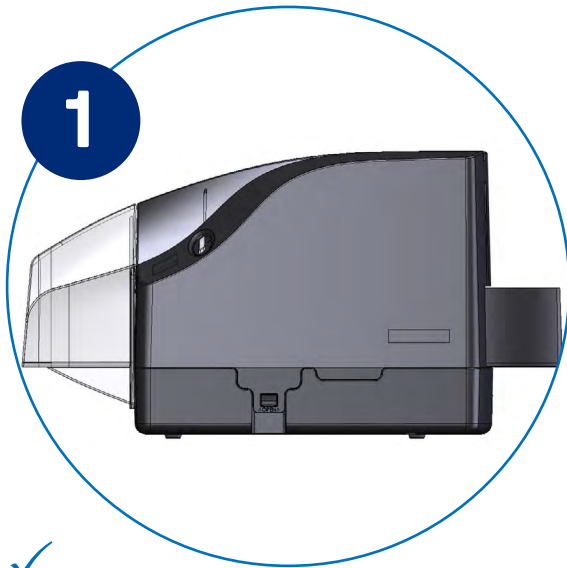

✓
CheXpress CX35 check scanner



✓
**100V-240V 50/60Hz voltage sensing,
external power supply and cord**

Digital Check part number: [82275802-000](#)



✓
USB 2.0 cable (10 ft)
Digital Check part number:
[CA0049](#)

Purchase at:
<https://store.digitalcheck.com/PN-CA0049>



✓
Ink cartridge – Digital Check part
number: [MS0083](#)

Purchase at:
<https://store.digitalcheck.com/PN-MS0083-Digital-Check-OEM-Replacement-1-Line-Inkjet-Cartridge>

NOTE: Ink cartridges are included
only with inkjet-equipped models

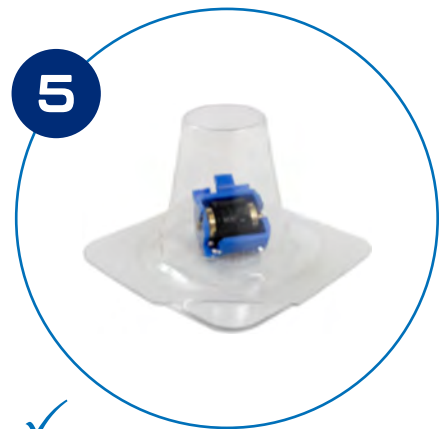

✓
Franker roller – Digital Check
part number: [153101](#)

Purchase at:
https://store.digitalcheck.com/PN-153101_2

Note: Franker rollers are included
only with franker-equipped models

CHEXPRESS CX35 INSTALLATION

Unboxing the CX35



Remove the power supply box and paperwork and set to the side.



Lay the box as shown above.



Pull all the remaining contents out of the box together.



Remove the top plastic insert to access the scanner. Grab the scanner from the rolled bag and from the bottom base and remove the tape and bag. (Blue Arrows)

CHEXPRESS CX35 FEATURES

External View of the CheXpress CX35

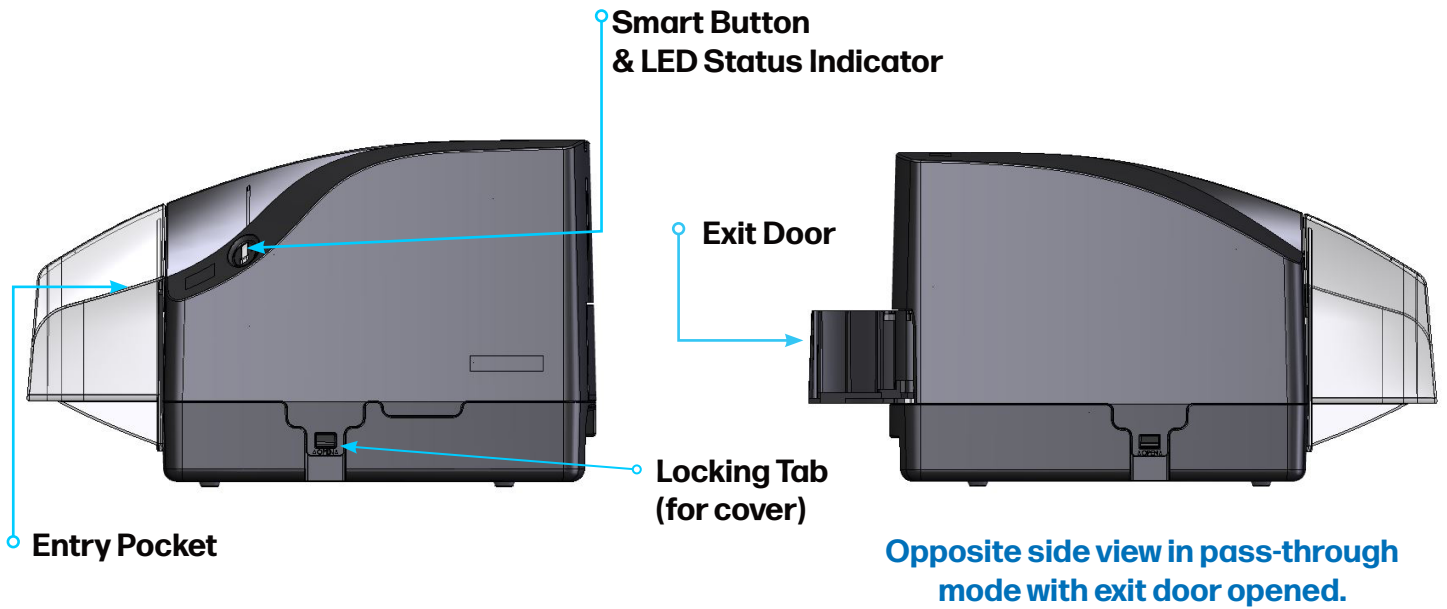

Rear View of the CheXpress CX35

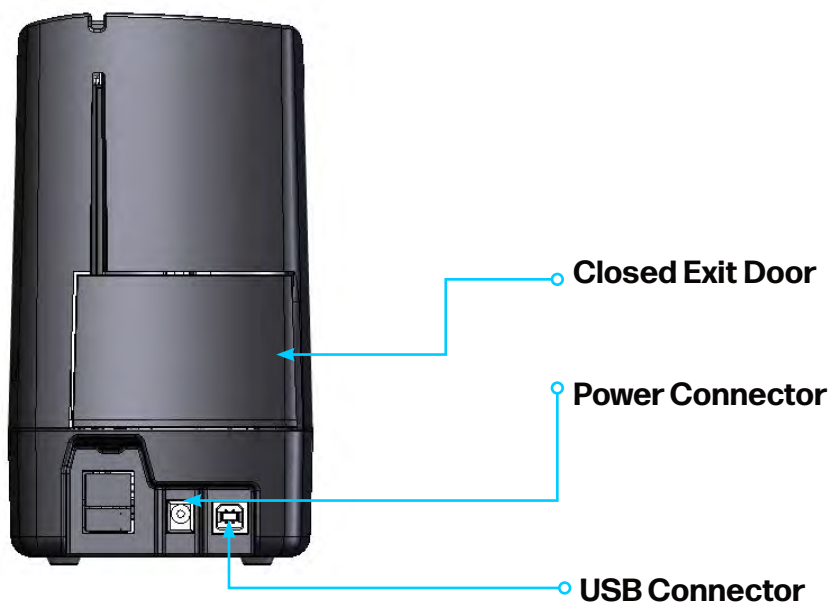

CHEXPRESS CX35 INITIAL SETUP

New User Notice

PLEASE NOTE: Do not connect the USB cable from the scanner to your PC before installing the drivers or the scanning application / software. Digital Check does not provide scanning software. Please contact your bank or other solution provider for further assistance with installing the driver or getting the scanning software set up or installed.

Digital Check only provides an optional driver installation utility and testing software. See the [Testing the Scanner section](#) for additional information.

Cable Connections and Scanner Placement

- When handling the CX35, grip it with two hands on the front and back of the scanner.
- Place the unit on a flat surface near the PC and away from direct light sources such as spotlights or desk lamps. Place the scanner in a position that is at least 6 inches away from any power supply, other electronic devices, pneumatic tubes at the teller window, etc. to avoid magnetic interference with the MICR read head.
- Connect the power cord to the power supply, and then plug the connector into the rear power connection port on the scanner.
- **Traditional USB Models:** Connect the USB cable by plugging it into the rear USB connection port before powering on the scanner.
- **RNDIS Models:** Connect the USB cable by plugging it into the rear USB connection port after powering on the scanner.

INSTALLING THE INK CARTRIDGE

Note: This step only applies to CheXpress CX35s that have the optional inkjet configuration. Follow these instructions when installing the ink cartridge for the first time, or when replacing an empty cartridge.

- Step 1:** Pull out on the locking tabs at the base of the scanner and remove the cover by lifting it vertically.

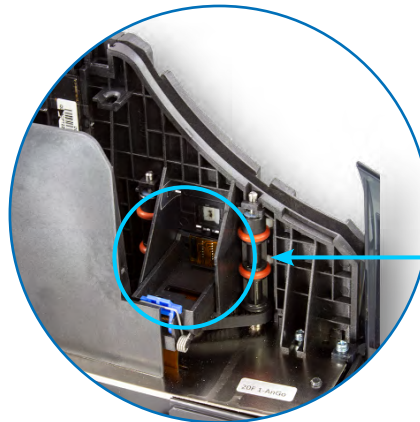
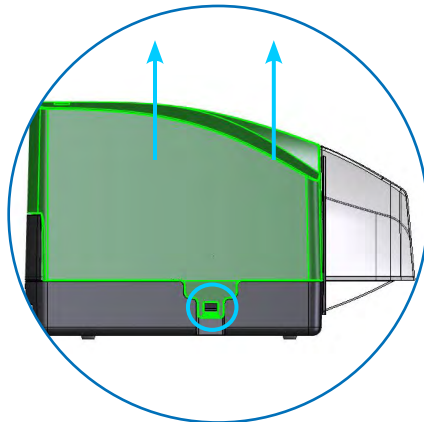

- Step 2:** Open the ink cartridge pouch and remove the protective tape covering the ink nozzles. Be careful not to touch the ink nozzle with your fingers or allow it to come in contact with anything else.

- Step 3:** Insert the nozzle end of the cartridge into the platform while keeping the end of the cartridge tilted slightly upward. Then, push down on the rear of the cartridge until it clicks or snaps securely into position.

Important: The top of the cartridge should appear level or flat when it is fully seated.



Insert the ink cartridge at a slight angle



Push down on the cartridge to fully seat



Correctly inserted

- Step 4:** Place the cover back onto the scanner.

Note: If the scanner must be transported by common carrier from one place to another, or will experience extended periods of inactivity, it is advisable to remove the ink cartridge from the scanner and seal it in an airtight bag. If the cartridge has not been used for an extended period of time, it might be necessary to clean the inkjet nozzles by gently blotting them with a towel dampened with water.

INSTALLING THE FRANKER ROLLER

Note: This step only applies to CheXpress CX35s that have the optional franker configuration. Follow these instructions when installing the franker roller for the first time, or when replacing a depleted franker roller. Replacement franker rollers can be purchased at Digital Check's web store: https://store.digitalcheck.com/PN-153101_2

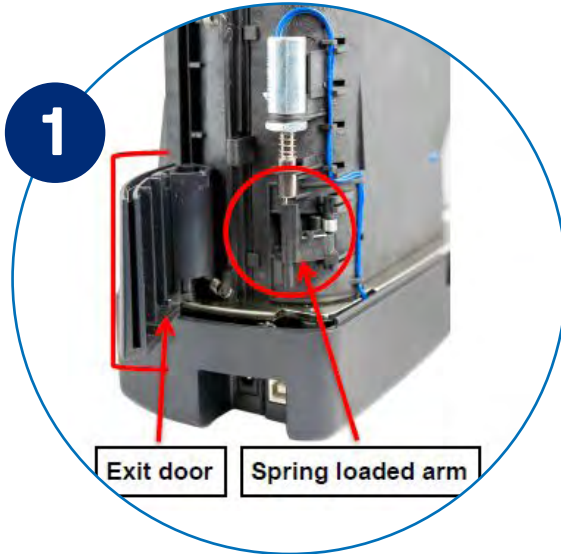

Remove the Main Scanner Cover. Open the Exit Door located at the rear of the scanner. Then, locate the Spring-Loaded Arm near the rear of the scanner.



Swing out and hold the Spring-Loaded Arm open (as shown). *The spring-loaded arm is NOT the metal part, but the plastic part underneath. The Franker Roller will slide onto a Post that is part of the Spring-Loaded Arm.

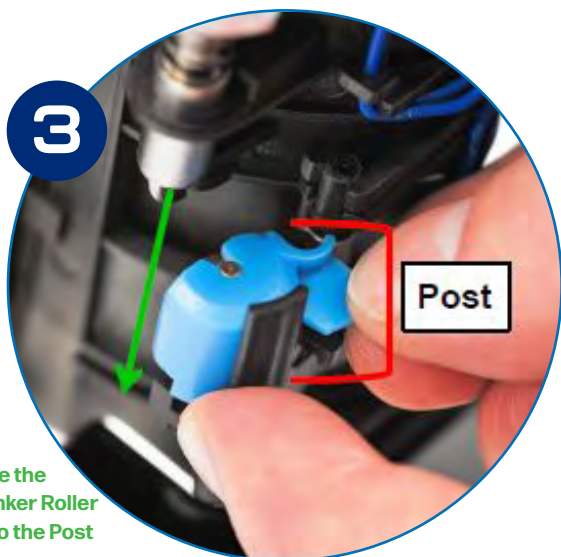

Slide the Franker Roller Onto the Post

Holding the Franker Roller (as shown), slide the Roller onto the Post.

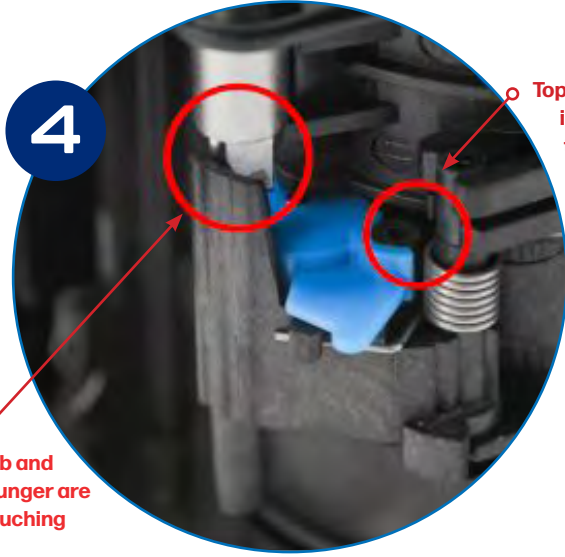

Tab and Plunger are Touching

Confirm that the Franker Roller is fully seated onto the Post. The top of the Post should be level with the Franker Roller (as shown).

The Tab on the Spring-Loaded Arm should be touching the metal Plunger (as shown). Close the Exit Door and replace the Main Scanner Cover.

EXIT DOOR FUNCTION AND OPTIONAL SCAN MODES

Scan Modes



Exit Door in
Closed Position



Exit Door in
Open Position

Scan & Return

This is the default and most commonly used mode. The exit door is in the closed position. The document will feed into the scanner and then return to the entry tray area after it has been scanned.

Pass Through

To enable this mode, the exit door must be open prior to launching a scanning application or demo software (e.g., ScanLite2). With the exit door in the open position, the documents will feed straight through the scanner and stack in the exit door. Up to five items can stack in the exit door. To revert to Scan & Return mode, close the exit door and restart the scanning application.

Note: On scanners equipped with the optional franker, the franker does not function in the Pass-Through mode.

LOADING ITEMS INTO THE SCANNER

The CheXpress CX35 is a single-feed scanner with a manual drop-and-slide style feeder which accepts just one item at a time. Please follow the steps below to ensure proper feeding.

- 1 Step 1:** Straighten any bent corners and remove staples or paper clips on items before scanning.
- 2 Step 2:** Insert a document into the entry tray with the front of the check facing towards the outside of the scanner.
- 3 Step 3:** Slide the item up to the limit line on the body of the scanner as indicated in image 3. The status LED light will turn Yellow/Orange when an item is detected. The bottom edge of the item should maintain contact with the tray when feeding it into the scanner.

Note: Depending upon the scan mode selected by the application and the open or closed position of the exit door, the document will either scan through the unit and stop in the rear exit door or scan and return to the entry tray for easy removal.



TESTING THE SCANNER

Installing the Optional USB Driver - CX35 Network (Ethernet over USB) Model Only

PLEASE NOTE: Do not connect the USB cable from the scanner to your PC before installing the drivers or the scanning application / software. Digital Check does not provide scanning software. Please contact your bank or other solution provider for further assistance with installing the driver or getting the scanning software set up or installed.

Digital Check provides only an optional driver installation, ScanLite 2 utility and testing software, that can be used for troubleshooting, verifying the connection to the PC and to test the various scanner functions.

Note: The USB driver and test software for the CX35 must be acquired from Digital Check support. Please call support at: **(1) 847-446-2285** or email: **support@digitalcheck.com**.

Once the USB driver is installed, use the following steps to complete the installation.

- 1** **Step 1:** Install the SPVA Driver provided by your bank in their install package. Follow the on-screen steps to complete the installation.
- 2** **Step 2:** Connect the scanner to the PC using the USB cable and plug in the power supply to the scanner and electrical outlet.
- 3** **Step 3:** Windows should now detect a new hardware device. The scanner is ready to be used with a scanning application or Digital Check test software.

Installing ScanLite2

The Digital Check demo and testing application ("ScanLite2") is a basic utility that allows the user to scan and view images, test the various scanner functions, verify the sensor status, and more. The instructions for installing and enabling the application will be included with the installation file.

Note: ScanLite2 does not save any image or MICR data to the PC. Once the scanned item disappears from the screen or the utility is shut down, the data is removed / cleared.

LED STATUS INDICATOR

LED Status Indicator and Smart Button Operation

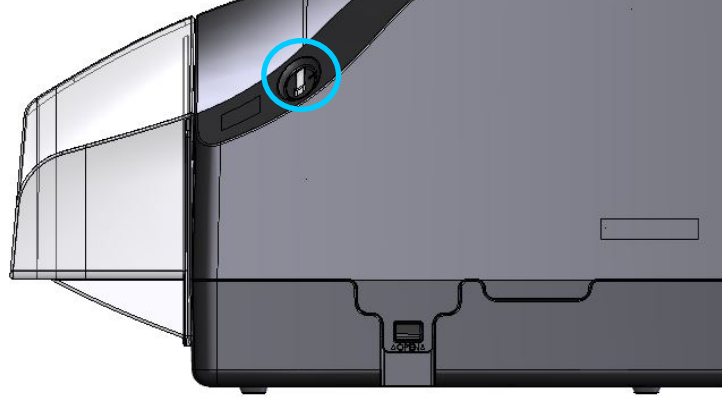

Off or No LED: ○

Scanner is not powered on. Press the Smart Button once to turn on. To turn off the scanner, press and hold the Smart Button.



Solid Red LED: ●

Scanner is not connected to computer. Check and reinsert both ends of the USB cable connecting to the PC and into the scanner and verify that the PC is turned on.



Slow Flashing Green LED: ● ○ ●

Scanner is in standby mode. This is the default state when an application is not controlling the scanner or has not yet acquired the scanner.



Solid Green LED: ●

A scanning application has successfully acquired the scanner and is ready to be used.



Solid Orange LED: ●

An item is in the entry pocket and waiting for the scanning process to begin.



Flashing Green LED: ● ● ●

Scanning in progress.



Flashing Red LED: ● ● ●

Indicates that the exit pocket is full, a scanning error has occurred, or that an item has stopped in the path.



Solid Blue LED: ●

Cleaning is required, and a scanning application has successfully acquired the scanner.

A Digital Check cleaning card is needed to clean the scanner. See the Cleaning the CX35 section for additional information on how to clean the scanner.

Cleaning cards can be purchased at Digital Check's web store:

https://store.digitalcheck.com/PN-HS0033_2

Note: Press the Smart Button 3 times within 3 seconds to start the scanner's cleaning mode.



Slow Flashing Blue LED: ● ○ ●

Cleaning is required, and the scanner is in standby mode. See the Cleaning the CX35 section for additional information on how to clean the scanner.



Flashing Blue LED: ● ● ●

The CX35 is in its cleaning mode. After running a cleaning card through the scanner wait for the drying timer to complete. Press the Smart Button once to exit the cleaning mode at any time.

ACCESSING THE CX35 INTERNALS

Removing the External Cover

The CX35 has a removable cover with two locking tabs on opposite sides of the scanner. Pull outward on the locking tabs located at the base of the scanner and lift the cover off to provide access to the interior of the scanner.



Pull the Locking Tabs Outward on Both Sides of the Scanner

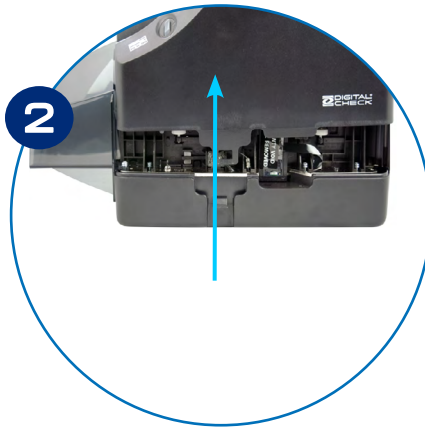

Then Lift the Cover Off



Accessing the Image Sensors

The image sensors can be easily cleaned by opening the outer image sensor door.

Step 1: Locate the image sensor door latch.

Step 2: Pinch the latch and the door will hinge open toward the rear of the scanner.

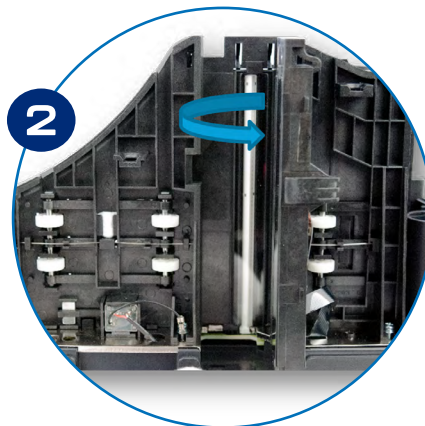
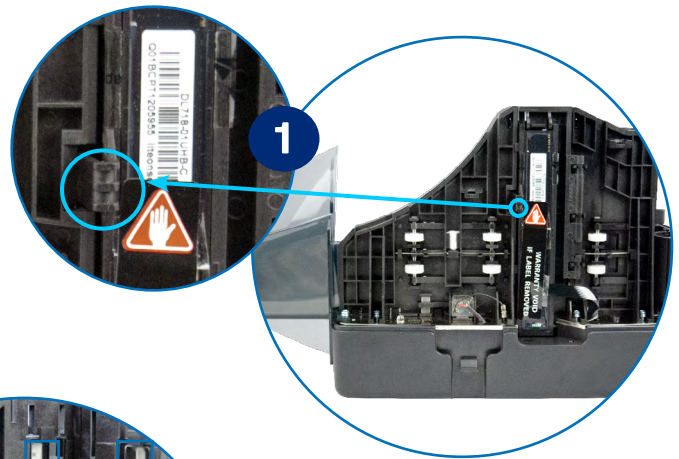

Door Swings Open

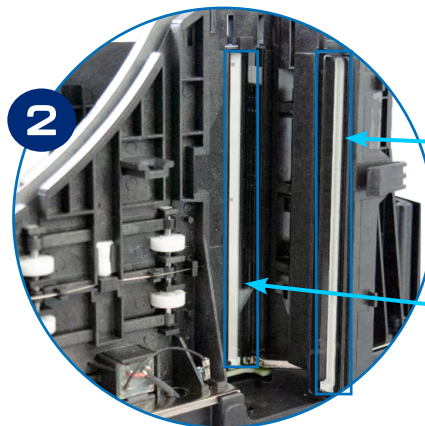

Front Sensor

Rear Sensor

Accessing the Internal Document Path

The document path of the CX35 offers a straight-through or U-path that can be accessed by opening the swing-out style, hinged door located at the rear of the scanner.

Note: Franker-equipped models will have the franker module mounted on the internal rear door. Accessing the door does not require removing the franker.

Step 1: Open the exit door.



Press the Left Side of the Exit Door to Open



Door Swings Open

Step 2: Locate the rear door latch indicated below.

Note: Franker equipped models will have the franker module mounted on the internal rear door. Accessing the door does not require removing the franker.



Rear Track Door Latch (Standard Model)



Rear Track Door Latch (Franker Model)

Step 3: Pinch the latch and the door will hinge outwards.



Rear Track Door

CHEXPRESS CX35 ROUTINE MAINTENANCE

CheXpress CX35 Maintenance Overview

Over time, ink, dirt, and dust particles will collect on the scanner rollers and in the document track and it is necessary to clean these areas to ensure reliable performance.

The Smart Button LED on the scanner will light up blue when the typical cleaning interval is reached. Use a Digital Check cleaning card to clean the scanner rollers. Cleaning cards can be purchased at: https://store.digitalcheck.com/PN-IS0033_2

See the Cleaning Process section for additional information. Inspect the quality of the captured images on a regular basis. If the image is affected by lines, streaks, or smudges etc., the image sensor glass should be cleaned.

Inspect the CX35 Document Track

In addition to routine drive roller cleaning, a periodic inspection of the entire document track area is also recommended. Remove any staples, paper clips, debris etc. that might have accumulated during use.

Use a can of compressed air to blow out the document track on a regular basis. Starting from the center of the path by the ink cartridge platform, blow the dust out toward the entry and exit pockets.

Cleaning the CX35 Image Sensor

See the [Opening the Image Sensor Door](#) section for instructions on how to access the image sensors.

To clean the image sensors, use a Digital Check cleaning swab or a clean, lint-free cloth dampened with isopropyl alcohol or other mild glass cleaning solution to clean the image sensor glass. Cleaning swabs can be purchased at: <https://store.digitalcheck.com/PN-IS0037>

Avoid using paper towels or napkins that leave dust particles on the glass. Be careful not to scratch the glass when cleaning or accessing the image sensors.

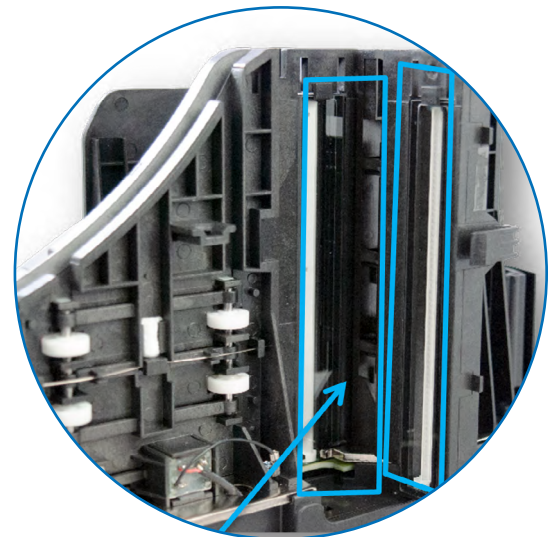

Image Sensors

Using the CX35 Cleaning Mode and a Scanner Cleaning Card

Use the Digital Check scanner cleaning cards (PN: IS0033 - available at https://store.digitalcheck.com/PN-IS0033_2) for regular cleaning maintenance.

Note: To maintain optimal performance, it is recommended to use a cleaning card, every 6 months or after every 10,000 documents scanned. This process takes less than five minutes to complete. It is advised to work out a schedule that allows regular cleanings to be performed.



***Required:** PN:IS0033

Step 1: Open the rear exit door.

Step 2: Press the Smart Button three times within three seconds to start the scanner's cleaning mode, indicated by a flashing blue light.

Step 3: Slide the cleaning card forward until it reaches the line indicated on the scanner cover. The scanner will begin the automated cleaning process.

Step 4: The scanner will automatically scrub the internal track with the cleaning card. Once fed through, remove the cleaning card from the exit pocket.

Step 5: The light will continue to flash blue as the built-in drying timer counts down. Once the timer completes, the blue light will turn off and the scanner is ready for use again.

Step 6: Close the exit door (unless using the scanner in the Pass-Through mode).

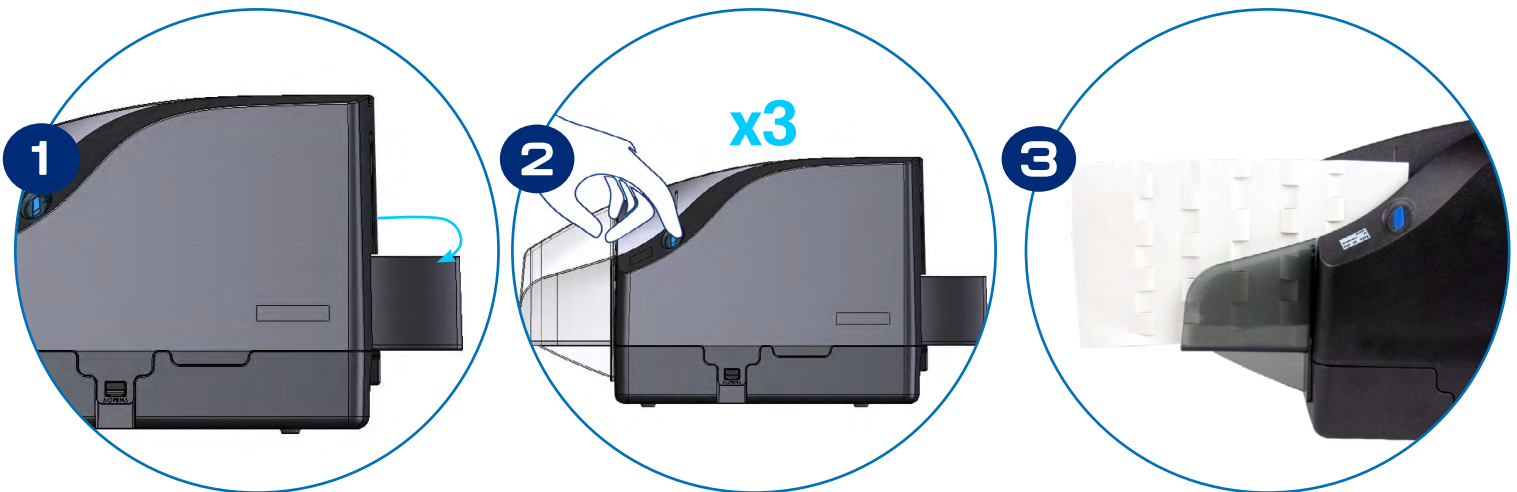

CHEXPRESS CX35 TROUBLESHOOTING

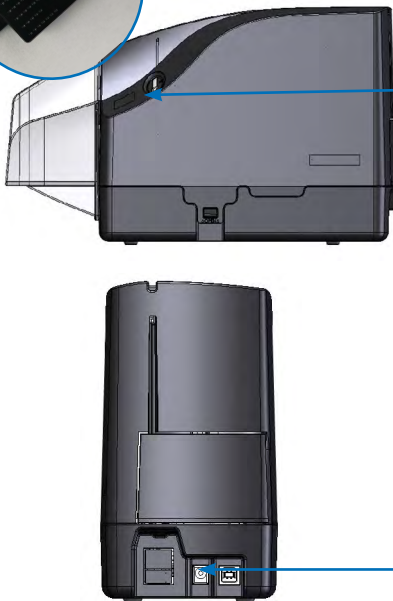

Connectivity

Status LED is not lit: ○

Check for a green light on the power supply. Reset all power connectors. Press the Smart Button on the scanner to turn on.

Status LED is solid red: ●

The USB cable is not connected to the PC, the PC is powered off, or the port is powered off. Unplug and reconnect the USB cable or try a different USB port on the PC.

Status LED is slowly flashing green: ● ○ ●

1.) Scanner is in standby mode waiting to be acquired by the application. If the application is unable to acquire the scanner, check the status of the USB driver.

2.) Device driver problem - Open Windows Device Manager and look at the Universal Serial Bus Controllers section.

- a.** If no driver is found it will show "CX35" under "Other Devices" as the device.
- b.** If the correct driver is found it will show "CheXpress".

Document Feeding Issues

If feeding problems occur, check the documents for bent or folded edges, and debris in the scanner document track. Ensure that all items have been aligned and inserted correctly.

Clearing Jams

If a jam occurs, the paper path must be cleared. To do this, try to advance the jammed document by pressing the Smart button for 2 seconds to engage the CX35's eject mode. If the document does not exit the track, grab the document with both hands and carefully wiggle the document back and forth while lifting at a 45-degree angle. See the [Accessing the CheXpress CX35](#) section for additional information on how to open and access the scanner.

Image Quality

If either streaking or fading appears on the images, the image sensor glass might require cleaning. See the [Cleaning the CX35 Image Sensors](#) section for additional information.

MICR Errors

- 1)** Confirm that the document has a known valid MICR line. Many errors are caused by low-quality magnetic printing on the check itself, not problems with the MICR head. If MICR errors are still occurring, verify that the CX35 power supply or another device's power supply is six or more inches away from the scanner. Next, inspect the track around the MICR assembly for debris, particularly metal objects.
- 2)** Drive-up teller pneumatic tubes and static buildup can also cause MICR errors; verify that the scanner is at least 6 inches away from these types of devices as well.

CHEXPRESS CX35 FREQUENTLY ASKED QUESTIONS

What is the Typical Cleaning Interval?

The recommended cleaning interval for the CX35 is approximately every 6 months or 10,000 documents scanned. See the [Cleaning the CX35](#) section for additional information.

What is the LED Status Light Sequence?

Once the CX35 is powered on, the proper LED sequence is for the LED to turn slow flashing green when the power supply and USB cables are connected to the scanner and to an outlet and the PC. This is followed by the LED turning solid green once the application or scanning software is running and detects the scanner. If the LED turns red, check the USB connection to the PC.

What About Avoiding MICR Read Head Interference?

Keep the CX35 power supply and others, small desk fans, pneumatic tubes at teller windows or similar devices 6-12 inches away from the scanner to keep them from interfering with the (MICR) magnetic read head.

How Long Does the Ink Cartridge Last?

Once opened, the practical life of the ink cartridge is 6 to 12 months depending on usage and environment. However, the rated character yield on the ink cartridge is between 5 to 7 million characters. Do not shake or drop the cartridge; this can cause printing to fail. Digital Check recommends keeping a spare cartridge available.

What is the Entry Tray Capacity?

The entry tray can accept one check at a time.

What is the Exit Pocket Capacity?

When the scanner is in pass-through mode with the exit door open, the exit door can stack up to five items.

Is It Safe to Use Common Cleaners and Sanitizers on the CX35?

When cleaning the exterior of the CX35, avoid the use of foaming and bleaching cleaners, as these could leave residue on the scanner or damage the scanner's finish. Do not use common household and office cleaners such as Windex on the scanner's internals or paper path. Only use specific Digital Check scanner cleaning products on the internal components or paper path.

CHEXPRESS CX35 SPECIFICATIONS

Unit Size:

Height: 7.47" (18.97 cm)
Width: 3.92" (9.96 cm)
Length: 9.38" (23.83 cm)
Weight: 3.72 lbs. (1.69kg)

Paper Size:

Document Height: 2.12" - 4.25" (54 - 108 mm)
Image Capture Height: Up to 4.17" (106 mm)
Document Length: 3.19" - 8.98" (121 - 228 mm)

Document Weight:

Scan & Return Mode: 16 - 28 lb. bond (60 - 105 gsm)
Pass Through Mode: 16 - 54 lb. bond (60 - 203 gsm)

Document Thickness:

Scan & Return Mode: 0.0032" - 0.0058" (0.081 - 0.147 mm)
Pass Through: 0.0032" - 0.0090" (0.081 - 0.229 mm)

Endorser: Programmable, single-line inkjet printer with user replaceable cartridge

In-Line MICR Recognition:

(Magnetic Ink Character Recognition) for E13B (North America) and CMC7 (Europe)
Optical Character Recognition to enhance MICR Read, further enhanced using DCC's Best Read® API function.

Transport Speed: 19.69 inches (50 cm) per second

Throughput:

Scan & Return Mode: Up to 30 DPM
Pass Through Mode: Up to 30 DPM

Interface: Standard USB 2.0

Scan Modes: Scan & Return, Pass Through

Scanning Method: Concurrent Two-Sided Duplex
(2 Scan Modules)

Scan Module: Contact Image Sensor (CIS)

Resolution: 600 DPI

Light Source: Tri-Color LEDs

Supported Compression:

JPEG (24-bit color, 8-bit grayscale)
BMP (24-bit color, 4-or-8-bit grayscale)
TIFF Group 4 B/W

DCC API Requirements:

DCC API Version 22.09 or newer recommended

Supported Operating Systems:

Windows 11/10, (x86 and x86-64)
macOS and Linux
(Contact Digital Check Technical Support for specific versions supported)

Electrical: Power consumption: 24 Watts

Input Voltage: 100 to 240 VAC, 50/60 Hz

Separate Standard Power Supply: Auto sensing for voltage

Product Warranty: 1 year warranty, pursuant to Digital Check Corp.'s Limited Product Warranty

Environmental:

Operating Temperature: 60° - 90° F (15° - 32° C)
Operating Humidity: 35 - 85% non-condensing

Certifications:

Safety: UL, cUL, CE, BIS
Emissions: FCC Class B
EMC: IEC CE
Efficiency: CEC V 115V - Power Supply
RoHS Compliant

FCC STATEMENTS

FCC - Class B

This equipment has been tested and found to comply with the limits for a Class B digital device, pursuant to part 15 of the FCC Rules. These limits are designed to provide reasonable protection against harmful interference in a residential installation. This equipment generates, uses, and can radiate radio frequency energy and, if not installed and used in accordance with the instructions, may cause harmful interference to radio communications. However, there is no guarantee that interference will not occur in a particular installation. If this equipment does cause harmful interference to radio or television reception, which can be determined by turning the equipment off and on, the user is encouraged to try to correct the interference by one or more of the following measures:

- Reorient or relocate the receiving antenna.
- Increase the separation between the equipment and receiver.
- Connect the equipment into an outlet on a circuit different from that to which the receiver is connected.
- Consult the dealer or an experienced radio/TV technician for help.

Digital Check Contact Information

Corporate Headquarters

Digital Check Corp.
630 Dundee Road
Suite 210
Northbrook, IL 60062
Phone: (847) 446-2286
Fax: (847) 441-5507

Manufacturing Facility

Digital Check Corp.
10231-A Trademark Street
Rancho Cucamonga, CA 91730
Phone: (909) 945-5106
Fax: (909) 948-3788

Visit us at www.digitalcheck.com

- ✓ Purchase Consumables
- ✓ Additional Product Information
- ✓ Technical Support and More



Digital Check, the Digital Check logo, TellerScan, and Best Read are registered US trademarks of Digital Check Corp. All other product names mentioned herein may be trademarks of their respective owners.

630 Dundee Rd, Suite 210 | Northbrook IL 60062
Tel: 847.446.2286 | Fax: 847.441.5507
www.digitalcheck.com